

HanleyLED
PHOENIX 4 **12 VDC**
 12V LED channel letter and sign cabinet illumination



Specifications

- SKU HLED-PF4180
- Beam angle 170° Phoenix wing optics
- Power (W)..... 1.8 W/mod (2.85 W/ft)
- Efficacy..... 114 lm/W
- Lumens 205 lm/mod (323.9 lm/ft)
- Modules/ft..... 1.58/ft (fully-stretched)
- Color temperature (CCT)..... 7000 K
- Environment IP65 waterproof
- Operating temp. -40° C to +60° C
- Storage temp. -40° C to +70° C
- Cascade 25 mods single-ended power feed
 50 mods double-ended power feed
- Packaging..... Anti-static bag, 50 modules (32 ft)/bag
- Warranty 10-Year Product/5-Year Limited Labor



For wide and bright cabinets and channel letters



20" max stroke

Constant Current

Recommended Coverage Chart

Model	Depth	Space between rows	Space between modules
Phoenix 4	3"	Single stroke 8", multiple stroke 6"	7"
	4"	Single stroke 10", multiple stroke 8"	
	5"	Single stroke 14", multiple stroke 10"	7.52"
	6"	Single stroke 18", multiple stroke 15"	
	7"	Single stroke 22", multiple stroke 15"	
8-12"	Single stroke 24", multiple stroke 18"		

Power Supply Options

Product	35 W	60 W	100 W	120 W	150 W	240 W
Phoenix 4	19 mods	33 mods	54 mods	66 mods	81 mods	132 mods

Product and depth may vary depending on face material and desired brightness. All spacing guidelines in this chart were done using 7328 White Acrylic faces. Other materials, thicknesses, and color can affect these guidelines in your sign. To ensure accuracy, it is recommended that you test the product in your specific application in a dark setting prior to installation. If you have concerns or questions about the materials you are using for your application please contact us for assistance.

Dimensions

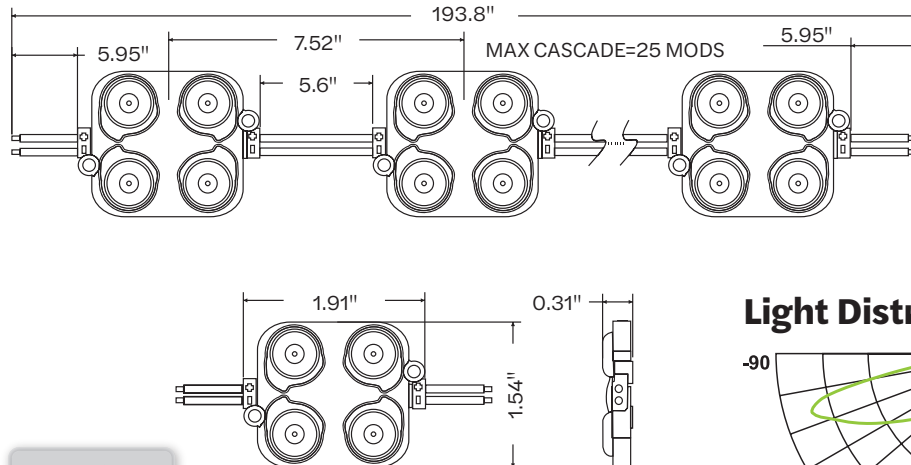

principalsloan.com
 325.227.4577
 3490 Venture Dr., San Angelo, TX 76905

Light Distribution

